

## **Table of Contents**

Chapter 1.	Important Safety Instruction.....	2
Chapter 2.	Product Introduction.....	4
Chapter 3.	Installation and Operation .....	5
3.1.	MTBS Unpacking.....	5
3.1.1.	Remove the PE foam of the MTBS.....	5
3.1.2.	Check attached accessories.....	5
3.2.	Selecting Installation Position.....	5
3.3.	Maintenance Bypass Front Panel .....	5
3.4.	Installation and Operation .....	8
Chapter 4.	Trouble Shooting.....	14
Chapter 5.	Specifications .....	15

# **User's Manual RAC-PDU-216G (Continuity 1000, 2000,3000)**

**Maintenance Bypass Switch  
For On-line Convertible UPS**

# Chapter 1. Important Safety Instruction

- Do not open the case, as there are no serviceable parts inside. Your warranty will be void.
- Do not try to repair the unit yourself, contact your local supplier or your warranty will be void.
- SAVE THESE INSTRUCTIONS--This manual contains important instruction that should be followed while installation and operation.
- Make sure that the AC Utility outlet is correctly grounded to avoid any possibility of unpredictable voltage leakage.
- Make sure the input voltage is within the windows stated in the specs sheet and the load connected is within the rated capacity.
- Should a strange noise, or smell occur, please turn off the unit and consult your local distributor for repair immediately.
- The equipment shall be operated under the maximum ambient temperature of 40°C.
- Do not defeat the safety purpose of the polarized or grounding-type plug, A polarized plug has two blades with one wider than the other. A grounding type plug has two blades and a third grounding prong. The wide blade or the third prong are provided for your safety. If the provided plug does not fit into your outlet, consult an electrician for replacement of the obsolete outlet.
- The equipment shall be installed near the wall socket outlet and that the disconnect device (plug on power cord and appliance coupler) shall be readily accessible.
- Caution: Risk of electric shock! Unit supplied by more than one power source, disconnection all the power supply connection (plug) is required to de-energized this unit before servicing.

- An overcurrent protective device and short-circuit protection device with adequate breaking (rupturing) capacity to interrupt the maximum fault current shall be incorporated external to the equipment between the equipment and the building installation

Model	Breaking capacity of overcurrent protective device	Model	Breaking capacity of overcurrent protective device
RacPDU-115A	20A	RacPDU-210D	20A (cTUVus)or 16A(CB)
RacPDU-120B	20A	RacPDU-216G	20A (cTUVus)or 16A(CB)
RacPDU-130H	30A		

## Chapter 2. Product Introduction

Characteristics:

There are two operation modes offered by the Maintenance Bypass Switch: One is UPS Mode(UPS Available) and the other is Utility Mode(Maintenance Bypass).

1. UPS MODE (UPS available): When the MTBS works on the UPS mode, the UPS is supplied energy from the Utility, then the UPS feeds it to the load connected.

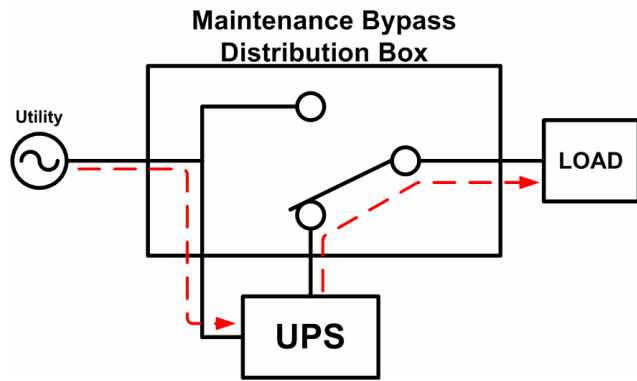

Figure 1: UPS mode of operation

2. UTILITY MODE(Maintenance bypass) : When the MTBS works on the Utility Mode, the load connected is supplied energy from the Utility directly, then the UPS can be turned off. No affection of the connected load will occur while maintenance or repair.

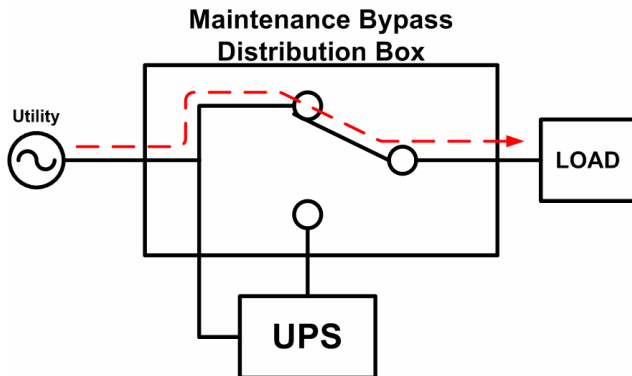

Figure 2: UTILITY mode of operation

## Chapter 3. Installation and Operation

### 3.1. MTBS Unpacking

#### 3.1.1. Remove the PE foam of the MTBS.

#### 3.1.2. Check attached accessories.

- User's Manual 1 copy
- Screws 1 set (M3\*6mm : 8 Pcs and M4\*6mm : 6 Pcs)
- Fixing metal kit(3 types) 1 set

### 3.2. Selecting Installation Position

It is necessary to select a proper environment to install the unit, in order to minimize the possibility of damage to the MTBS and extend its life. Please follow the instructions below:

- Please ensure the installation site environmental conditions are in accordance with working specifications to avoid overheat and excessive moisture.
- Do not place the MTBS in a dusty or corrosive environment or near any flammable objects.
- This MTBS is not designed for outdoor use.

### 3.3. Maintenance Bypass Front Panel

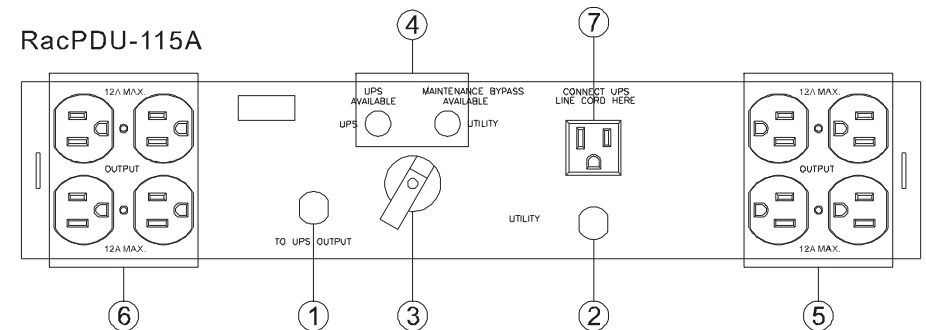

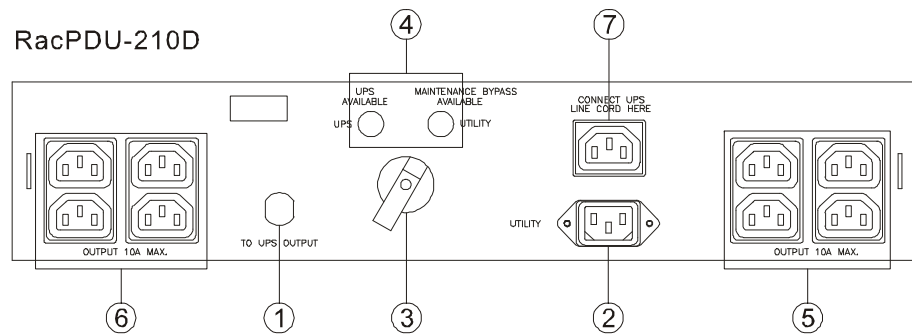
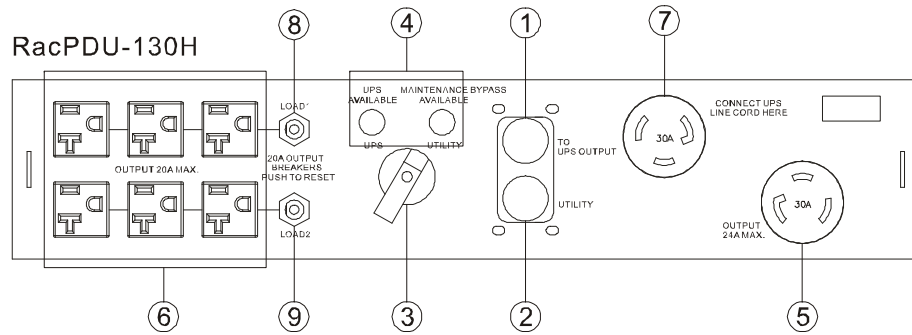
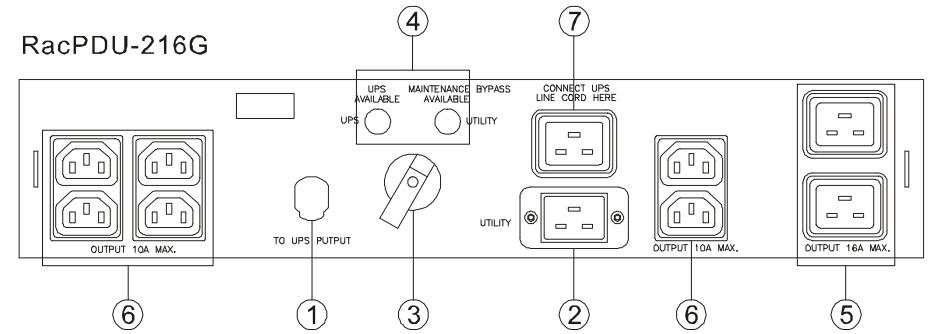
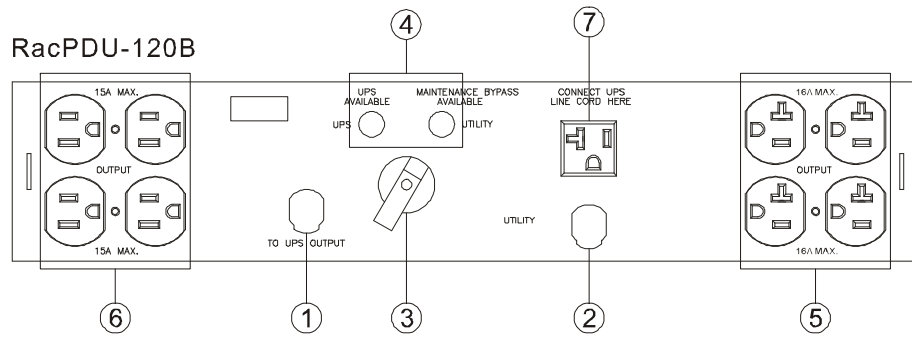

Figure 3: MTBS front Panel

- ① UPS Sockets : Connect to the UPS output sockets.
- ② Input Socket : Connect to the Wall Receptacle.
- ③ CAM SWITCH : Maintenance Bypass Switch.
- ④ Lamps : UPS and Utility
- ⑤&⑥ Load Input Sockets : Connect to the Load.
- ⑦ UPS Input Socket : Connect to the UPS Input.
- ⑧&⑨ Load Input Breaker.

### 3.4. Installation and Operation

The installation of the MTBS has three different methods. You may choose one of them in accordance with your need. For installation procedure, please refer to Figure 3.

#### Installation Procedure:

1. Unpack the package and keep the package for future use.
2. Check if any damage occurred during transportation. If yes, please contact with your local agent.
3. Check to see if the input power cord/socket, UPS I/P & O/P cables, load receptacle are complied with the ones you have in the UPS.
4. Shut down the load connected to the UPS and remove the input cable of the load from the UPS, then turn off the UPS and remove the input power cord of the UPS from the wall receptacle.

#### 5. Hardware Installation

##### Rack Mount Installation

Fasten the Fixed Plate 1 as Figure 5 to the MTBS as shown in Figure 6.

6. Make sure the CAM Switch(Maintenance Bypass Switch) is at "Utility" position, then plug the input power cord with "Utility" sign to the wall receptacle, then the orange lamp of the MTBS will light up.

**\*Caution :** The MTBS has already had electrical energy flowed through now.

7. Connect the input power cord of the UPS to the socket with a sign of "CONNECT UPS LINE CORD HERE" of the MTBS.

**\*Caution :** The UPS has already had electrical energy flowed through now.

8. Connect the plug with a sign of "TO UPS OUTPUT" of the MTBS to the output socket of the UPS.
9. Please connect the load evenly to the sockets with a sign of "OUTPUT" of the MTBS. The load is backed up by the Utility now.
10. Make sure the load connected is complied with the voltage and current of the UPS.
11. Please turn on the UPS according to the operation manual of the UPS, then the green lamp of the MTBS will light up.

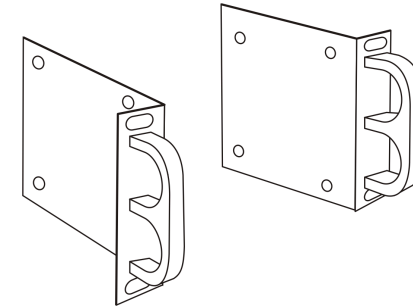
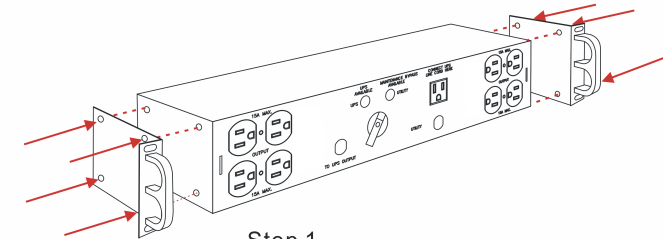
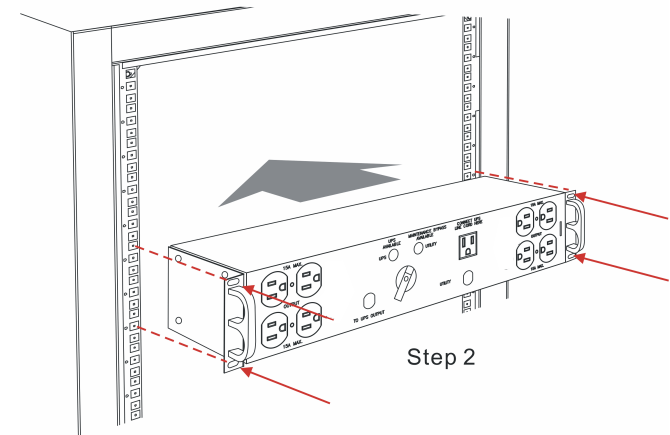

Figure 5: Fixed Plate 1



Step 1



Step 2

Figure 6: Rack Mount Installation

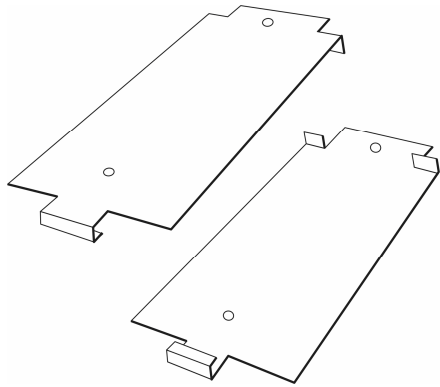

Figure 7: Fixed Plates 2

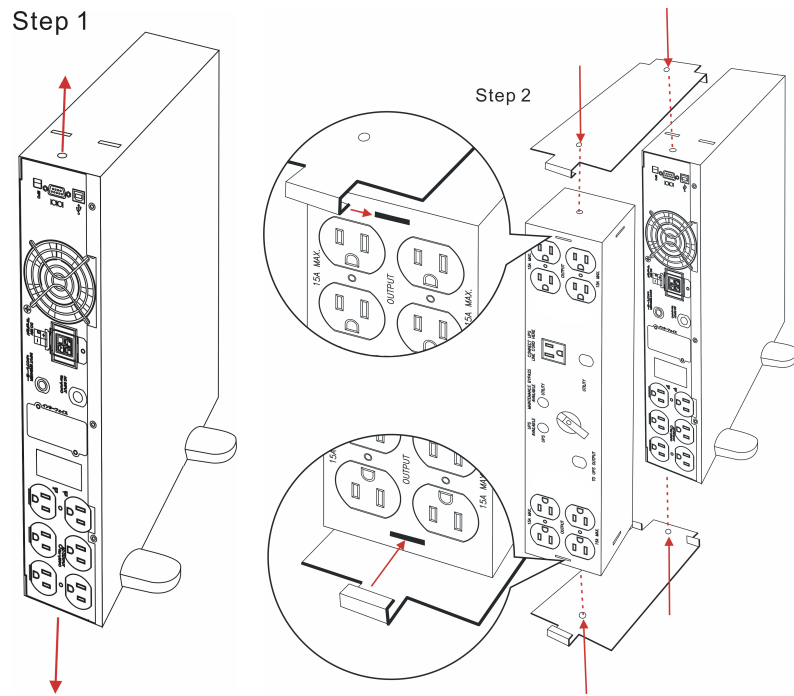

Figure 8: Convertible Installation(1)

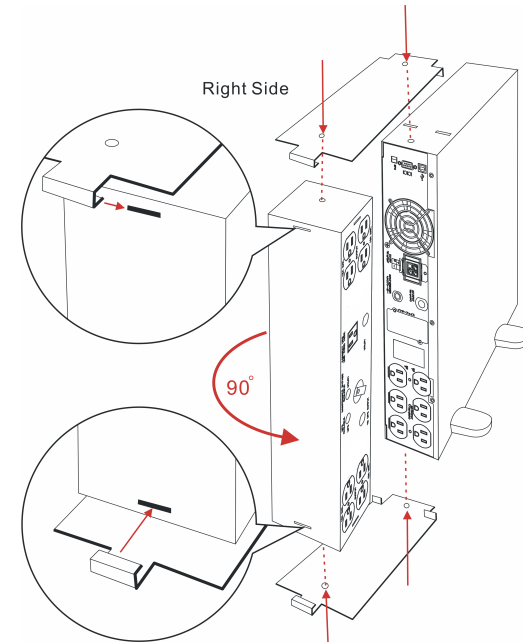

Figure 9: Convertible Installation(2)

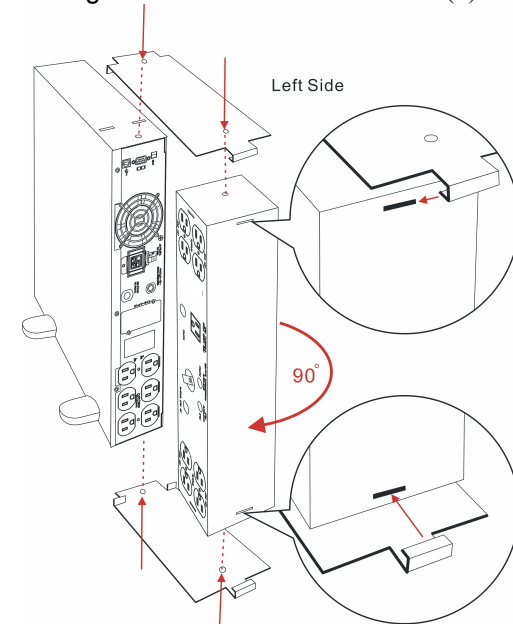

Figure 10: Convertible Installation(3)

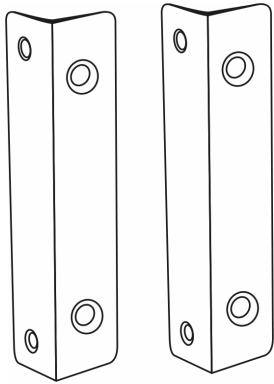

Figure 11: Fixed Plates 3

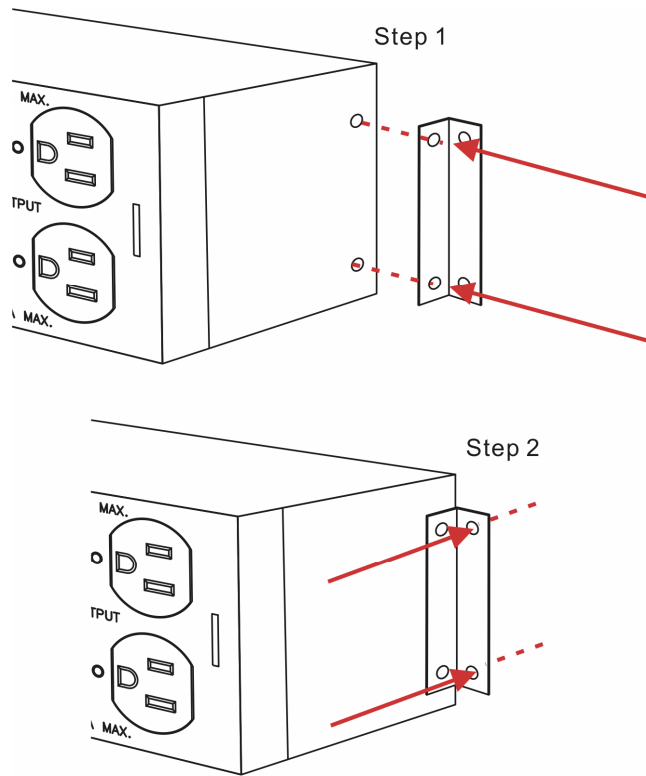

Figure 12: Wall Mount Installation

### Operation Procedure:

Make sure that you may switch the modes according to the following procedure:

#### 1. UPS MODE => UTILITY MODE(Maintenance bypass)

Step 1: Make sure the orange lamp is lit. If not, please refer to Trouble Shooting.

Step 2: Switch the CAM Switch (Maintenance Bypass Switch) from UPS to Utility.

Step 3: Turn off the UPS.

Step 4: Remove the connection between the UPS and the MTBS.

Step 5: Your maintenance or replacement of the UPS may be proceeded.

#### 2. UTILITY MODE(Maintenance bypass) => UPS MODE

Step 1: Connect the input and output of the UPS to the MTBS, then turn on the UPS in accordance with the operation manual of the UPS.

Step 2: Make sure if the Green lamp of the UPS is lit. If not, please refer to the Trouble Shooting.

Step 3: Switch the CAM Switch (Maintenance Bypass Switch) from Utility to UPS, then the load connected will be supplied by the UPS now.

## Chapter 4. Trouble Shooting

Should not your MTBS operate normally, you may make some proper adjustments and replacements as indicated below. Should the MTBS still operate abnormally, please consult with your local agent immediately.

Situation	Checked Items	Solution
Orange lamp is not lit.	No Utility	Call a professional electrical technician for service.
	The input power cord of the MTBS is not connected to the wall receptacle properly.	Connect it to the wall receptacle.
Green lamp of the UPS is not lit.	UPS has no output.	Please refer to the operation manual of the UPS for start up the UPS properly.
	The input and output of the UPS are not connected to the MTBS properly.	Connect them to the MTBS properly.
Some or all of the loads are not supplied with electrical energy.	Check to see if the circuit breaker of the MTBS is tripped.	Reset the circuit breaker of the MTBS.
No electrical energy supplied after reset of the circuit breaker of the MTBS	Over current in the MTBS output sockets.	Reduce the load connected.

## Chapter 5. Specifications

Transfer Time	< 6 ms
Operational Temperature	32°F to 104°F (0°C to +40°C)
Storage Temperature	-4°F to 140°F (-20°C to +40°C)
Dimension: W×D×H(mm)	87×77×440
Shipping Dimension: W×D×H(mm)	325×155×514
Net Weight(kg)	2.7*
Net Weight with Shipping (kg)	3.8*
Operating Altitude:	Up to 6560 ft (2000m)

\*Base on RacPDU-115A

※You may choose a proper type listed below to comply with the UPS you have.

Model Name	Rating	AC Input Plug (Receptacle)& cord length	Connect to UPS Input	Connection to UPS Output & cord length	Output Receptacles/protection
RacPDU-115A	120V 1KVA	NEMA 5-15P Attached 10-foot cord	NEMA 5-15P	NEMA 5-15P *1 Attached 6-foot cord	NEMA 5-15R *8
RacPDU-120B	120V 2KVA	NEMA 5-20P Attached 10-foot cord	NEMA 5-20P	NEMA 5-20P *1 Attached 6-foot cord	NEMA 5-15R *4 NEMA 5-20R *4
RacPDU-130H	120V 3KVA	NEMA L5-30P Attached 10-foot cord	NEMA L5-30P	NEMA L5-30P *1 Attached 6-foot cord	NEMA 5-20R *6 with 20A circuit breaker *2 NEMA 5-30R *1
RacPDU-210D	230V 2KVA	N/A	IEC C14	IEC C14 *1 Attached 6-foot cord	IEC C13 *8
RacPDU-216G	230V 3KVA	N/A	IEC C20	IEC C20 *1 Attached 6-foot cord	IEC C19 *2 IEC C13 *6